

# SEMSF13

up to 1700 rows/hour - ROW SEEDER

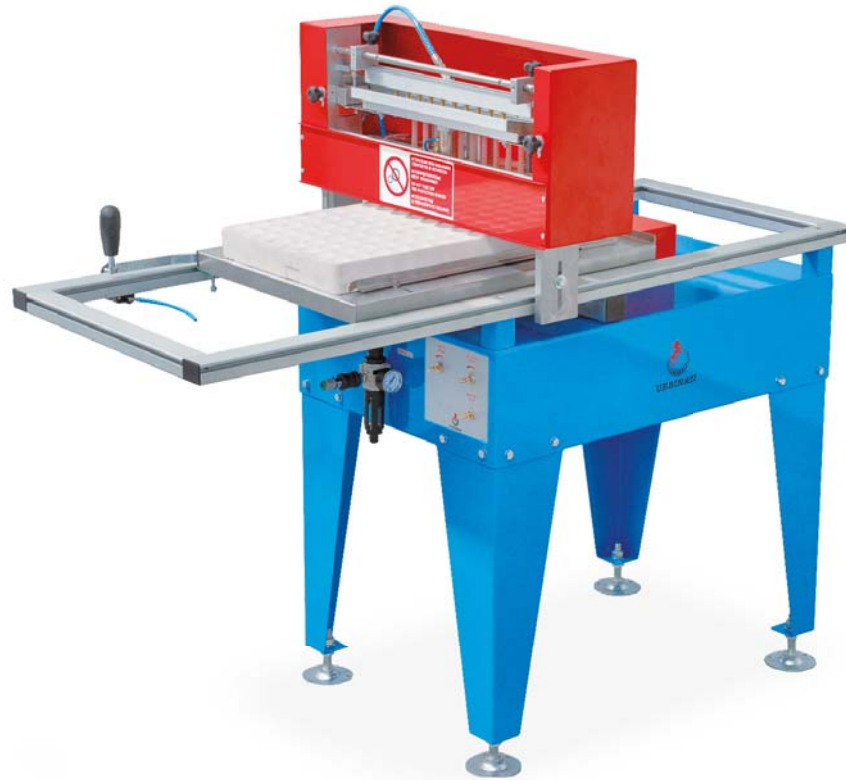

# VARIANT

TRANSVERSAL - up to 1.700 rows/hour



## MACHINE DESCRIPTION

The SEMSF13 row seeder with pneumatic working is suitable for every kind of tray and seed, naked and pelleted.

Complete of automatic dibbler.

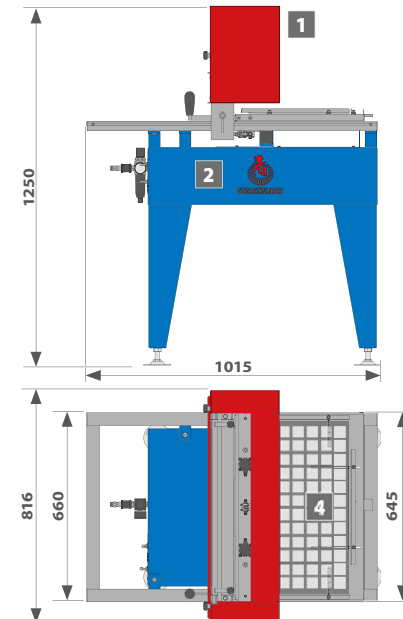
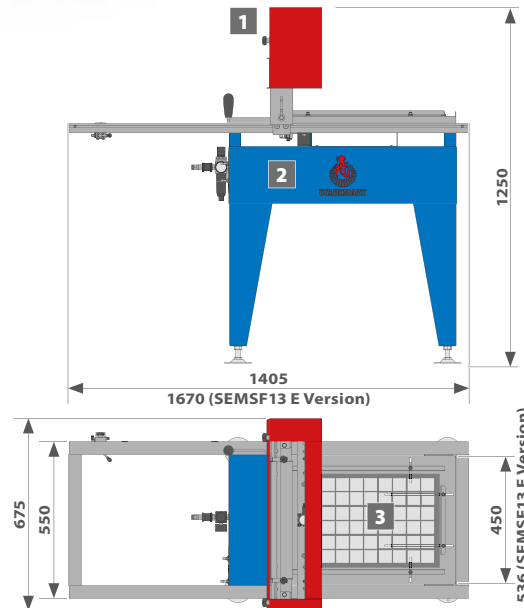

## MACHINE DESCRIPTION

Thanks to the transversal positioning of the tray, the "T" TRANSVERSAL variant of the row seeder, allows a higher hourly production.

## TECHNICAL DATA

HOURLY PRODUCTION (max)

TRAYS DIMENSIONS (max)

TRAYS HEIGHT (max)

WEIGHT

VACUUM PUMP

AIR CONSUMPTION (max)

KIT OF NOZZLES



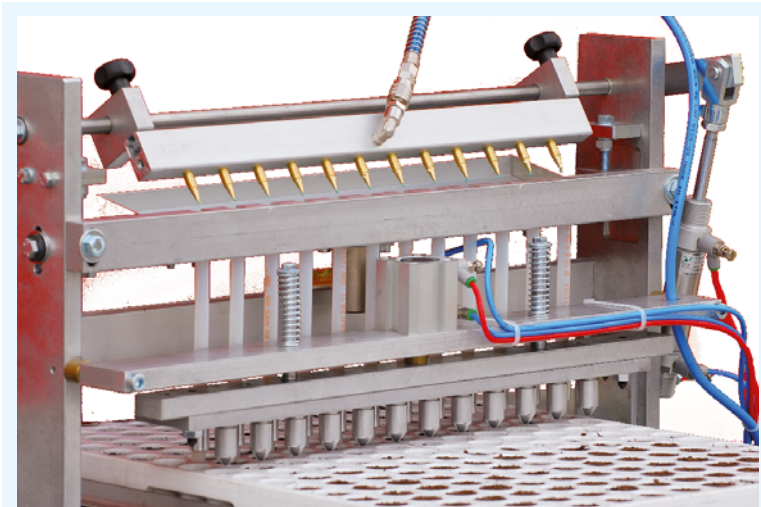

Seeding bar kit assembled on the seeder.

TECHNICAL SPECIFICATIONS

- 1 Seeding head with nozzles and dibbler.
- 2 Movement of the seeding table with automatic step.
- 3 Longitudinal tray advancement.
- 4 Transversal tray advancement.

page 40-43

ACCESSORIES

6 10

M.U.	SEMSF13	SEMSF13 E	"T" VARIANT
rows/hour	1700	1700	1700
mm	600x400	750x500	400x600
mm	150	150	150
kg	80	85	85
model	Venturi System	Venturi System	Venturi System
l/min	190	190	190
mm	0,20 - 0,25 - 0,30 - 0,35 - 0,40 - 0,50 - 0,60 - 0,70		

The seeding bar kit is supplied according to the seed and to the trays used.

Kit includes:

- 1 **Nozzle bar** with spacer for nozzles supplied with the seeder.
- 2 **Tube descent bar.** Inner diameter available for the descent tubes: 6, 8, 12 or 17 mm.
- 3 **Dibbler bar.**
- 4 **Advancement bar.**

Other accessories:

- 5 **Silicone** nozzles.
  - 6 **Silicone** nozzles with **brass** end.
  - 7 **Multi-seed** nozzles.
  - 8 **Single-hole** nozzles (equipped with the machine).
- Bigger **vacuum**.

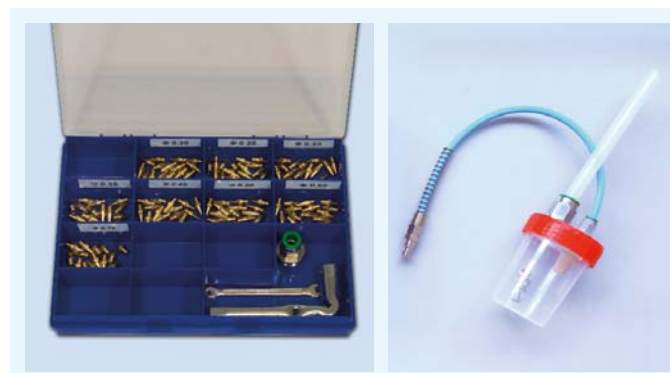
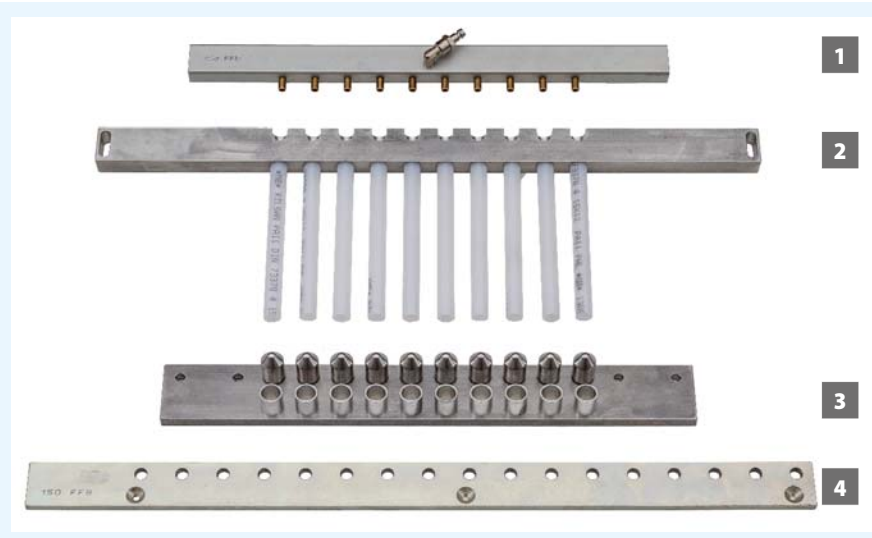

Nozzles kit - tools and remaining seed aspirator supplied with the machine.



Control panel.



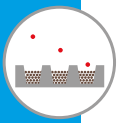

# DETAILS

## SEEDING



**Ergonomic panel** for an easy control of all machine's functions.

**INCLUDED ON:**

ALL SEEDING LINES



**Colour touch-screen** with intuitive graphic easy to use for the operator.

**INCLUDED ON:**

ALL SEEDING LINES

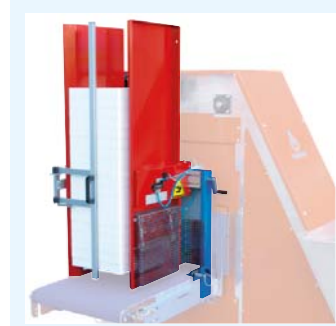

Tray denester **with 2 movements**, adjustable with one single handle.

**INCLUDED ON:**

ALL SEEDING LINES

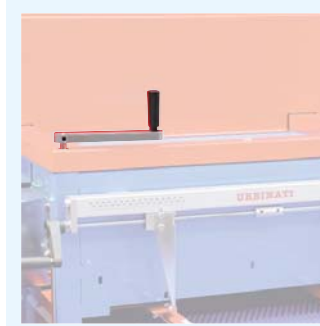

The adjustment of the tray's height, width and soil density is made with **functional handles**.

**INCLUDED ON:**

ALL SEEDING LINES

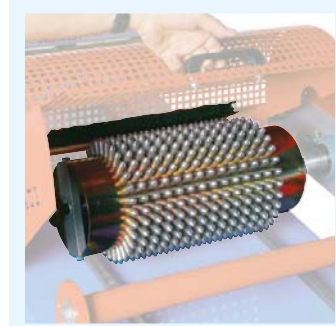

**Driven dibbler** with cleaning brush.

**INCLUDED ON:**

SIGMA80, ALFA65, BETA65/65C, LAMBDA65/65C, YPSILON65/65C



Double blow bar with more holes for the **seeding singulation**.

**INCLUDED ON:**

SIGMA80, ALFA65, BETA65/65C, LAMBDA65/65C, YPSILON65/65C



Easy and fast adjustment of seeding system's height and dibbler's depth, thanks to **comfortable handles**.

**INCLUDED ON:**

SIGMA80, ALFA65, BETA65/65C, YPSILON65/65C, KAPPA65C



**Electric adjustment** of the drums' height with touch-screen.

**INCLUDED ON:**

LAMBDA65/65C



**Adjustable speed hammers.** The vibration helps placing the seeds in the center of the holes.

**INCLUDED ON:**

SIGMA80, ALFA65, BETA65/65C

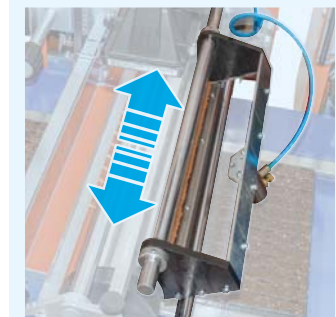

**Oscillating seed holding plate** to distribute the seeds **uniformly** all over the working width. It enables to work also with a small quantity of seed.

**INCLUDED ON:**

SIGMA80, ALFA65, BETA65/65C, LAMBDA65/65C, YPSILON65/65C

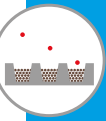

Thanks to the **modularity of the design**, our seeding lines and seeders **share common parts**.  
The following pictures show some of the **most significant details**.

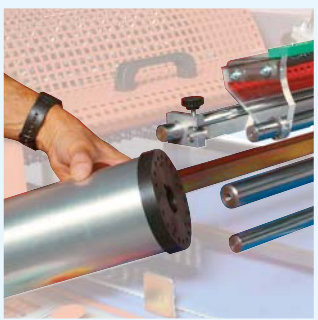

**Fast and easy changing** of the drum without any tool.

**INCLUDED ON:**

SIGMA80, ALFA65, BETA65/65C, LAMBDA65/65C, YPSILON65/65C



**High-power vacuum pump:** enables to use the same drum for the variety sowing of different weight.

**INCLUDED ON:**

SIGMA80, ALFA65, BETA65/65C, LAMBDA65/65C, YPSILON65/65C

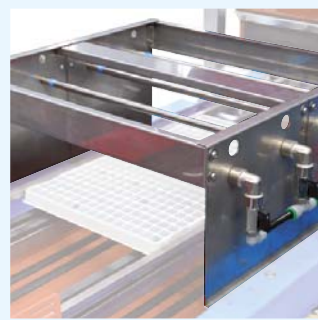

The drilled bar system, produced by CNC machines, makes the **watering uniform**.

**INCLUDED ON:**

ALL SEEDING LINES

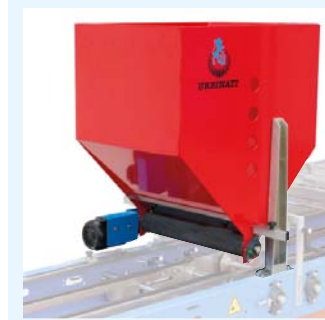

**Drum vermiculite coverer:** guarantees the best uniformity with all the granulometries.

**INCLUDED ON:**

ALL SEEDING LINES



Easy and functional **balance stacker**.

**INCLUDED ON:**

ALL SEEDING LINES



**Fast and self-centering system** for width adjustment of the trays with handles.

**INCLUDED ON:**

SIGMA80, ALFA65, BETA65, LAMBDA65, YPSILON65

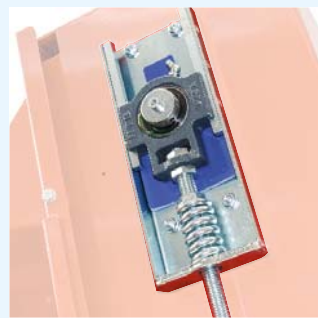

**Engineering solutions** aimed to reduce and simplify the maintenance. For example, visible bearings lubricator, spring tensioner on chains, etc.

**INCLUDED ON:**

ALL SEEDING LINES



**Strong manufacturing** and lasting materials, for example stainless steel and hot galvanizing for parts in contact with soil and water.

**INCLUDED ON:**

ALL SEEDING LINES



Seeding plate on sliding guides for a **fast change**.

**INCLUDED ON:**

SEMBLOCK



**URBINATI**



# ACCESSORIES

## SEEDING

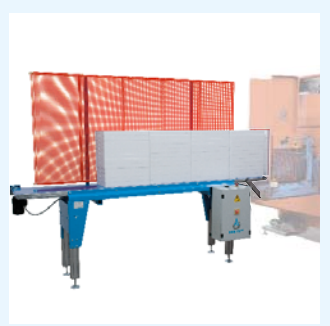

Feeding belt for single trays or empty stacks for denester.

L = 3300/4300/5300/6300 mm.

1

**AVAILABLE ON:**

ALL SEEDING LINES



Denester for heavy plastic trays at injection in polypropylene PP.

2

**AVAILABLE ON:**

ALL SEEDING LINES

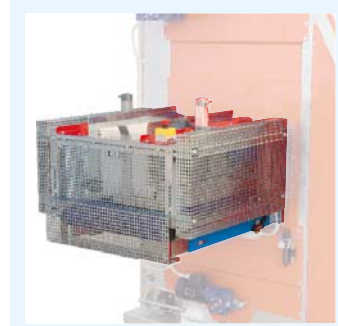

Electropneumatic denester with 3 movements for thermoformed trays (PE - PET).

3

**AVAILABLE ON:**

ALL SEEDING LINES



Adjustment device for trays with legs.

4

**AVAILABLE ON:**

ALFA65, BETA65/65C, LAMBDA65/65C, YPSILON65/65C, KAPPA65C

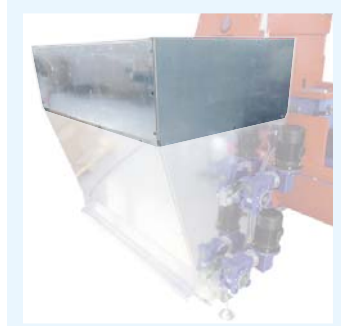

Peat hopper extension of 900 l.

5

**AVAILABLE ON:**

SIGMA80, ALFA65, BETA65, LAMBDA65, YPSILON65



Flat dibbler for seeding of aromatic plants and multiseeding.

6

**AVAILABLE ON:**

ALL SEEDING LINES AND SEEDERS with drum seeding system



Oscillating cleaning brush for the dibbler, useful with wet soil.

7

**AVAILABLE ON:**

SIGMA80, ALFA65, BETA65/65C, SEMBETA65

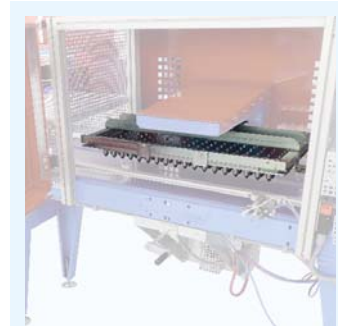

Plate dibbler mod. NI for depth bigger than 20 mm and for seeders assembled with nr. 3 sowing drums.

8

**AVAILABLE ON:**

LAMBDA65/65C, SEMLAMBDA65



Complete drum seeding kit: it includes one dibbler, one seeding drum and two nozzle bars.

9

**AVAILABLE ON:**

SIGMA80, ALFA65, BETA65/65C, LAMBDA65/65C, YPSILON65/65C, SEMBETA65, SEMLAMBDA65, SEMYPSILON65



Seeding bar kit: it includes one nozzle bar, one tube descent bar and one dibbler bar.

10

**AVAILABLE ON:**

KAPPA65C, SEMKAPP65, SEMSF13

These accessories **improve further the performance** and the productivity of our seeding lines and seeders.  
Our **engineering dept.** is at your disposal **to suggest the best solutions** for your needs.



**11** Sowing drum with **multi-hole nozzles** for aromatics, microgreens etc.

**AVAILABLE ON:**

SIGMA80, ALFA65, BETA65/65C, LAMBDA65/65C, YPSILON65/65C, SEMBETA65, SEMLAMBDA65, SEMYPSILON65, SEMBLOCK



**12** Seeding drum with **raised nozzles** for difficult seeds, for example tagetes, zinnia, etc.

**AVAILABLE ON:**

LAMBDA65/65C, YPSILON65/65C, SEMLAMBDA65, SEMYPSILON65



**13** **Air bars** with labyrinths suitable to work with **big seeds**.

**AVAILABLE ON:**

SIGMA80, ALFA65, BETA65/65C, LAMBDA65/65C, YPSILON65/65C, SEMBETA65, SEMLAMBDA65, SEMYPSILON65



**14** **Drum for big seeds**, as for ex. acorns.

**AVAILABLE ON:**

ALFA65, BETA65/65C, SEMBETA65

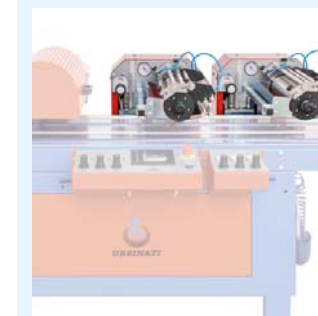

**15** **Second/third sowing drum.**

**AVAILABLE ON:**

Second drum: SIGMA80, ALFA65, BETA65/65C, SEMBETA65  
Second/third drum: LAMBDA65/65C, SEMLAMBDA65



**16** Belt for the **recycling soil** for trayfiller.

**AVAILABLE ON:**

BETA65C, LAMBDA65C, YPSILON65C, KAPPA65C



**17** **Seed inspection** to easily check the sown trays.

**AVAILABLE ON:**

ALL SEEDING LINES AND SEEDERS AND *except* SEMSF13



**18** **Sand and soil coverer** with brush to clean the trays.

**AVAILABLE ON:**

ALL SEEDING LINES AND SEEDERS *except* SEMSF13

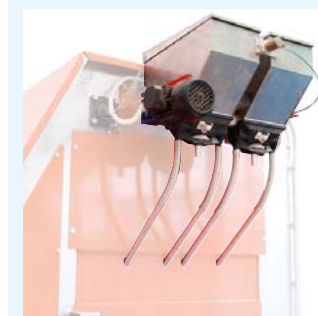

**19** **Fertilizer distributor.**

**AVAILABLE ON:**

SIGMA80, ALFA65, BETA65, LAMBDA65, YPSILON65



**20** **Loading and automatic recycling** of vermiculite with hopper capacity 240 l.

**AVAILABLE ON:**

ALL SEEDING LINES AND SEEDERS *except* SEMSF13



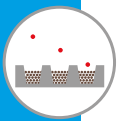

# ACCESSORIES

## SEEDING



**Soil recycle**, to recover the exceeding soil. **21**

**AVAILABLE ON:**

ALL SEEDING LINES AND SEEDERS  
*except SEMSF13*



**Triget watering unit:** on request as alternative to the watering unit with drilled bars. **22**

**AVAILABLE ON:**

ALL SEEDING LINES AND SEEDERS  
*except SEMSF13*

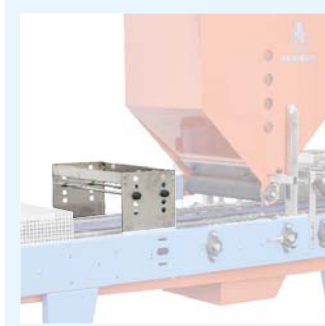

**Second water unit** with nr. 2 drilled bars: mainly needed to increase the soil watering. **23**

**AVAILABLE ON:**

ALL SEEDING LINES AND SEEDERS  
*except SEMSF13*



**ETC automatic labelling machine:** to print and apply labels on the trays coming out from the denester. **24**

**AVAILABLE ON:**

ALL SEEDING LINES



**Black ink jet printer mod. U2011:** fixed version for moving trays to write on the long side of the tray. **25**

**AVAILABLE ON:**

ALL SEEDING LINES AND SEEDERS  
*except SEMSF13*



**Black ink jet printer mod. U2011:** moving version for trays in fixed position. **26**

**AVAILABLE ON:**

ALL SEEDING LINES

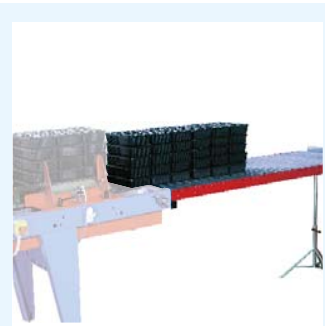

**Automatic stacker** with discharge on the free roller belt, length up to 2000 mm. **27**

**AVAILABLE ON:**

ALL SEEDING LINES AND SEEDERS  
*except SEMSF13*



**Automatic stacker** with discharge on variable length belt for high productivity. **28**

**AVAILABLE ON:**

ALL SEEDING LINES AND SEEDERS  
*except SEMSF13*



**Fast and self-centering system** for width adjustment of the trays with handles. **29**

**AVAILABLE ON:**

BETA65C, LAMBDA65C,  
YPSILON65C, KAPPA65C,  
SEMLAMBDA65, SEMYPSILON65,  
SEMBLOCK, SEMKAPPA65



**Aluminium seeding plate** with seed drop drawer with pneumatic opening. **30**

**AVAILABLE ON:**

SEMBLOCK

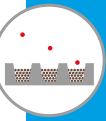

31

Soil feeding of the covering unit.

AVAILABLE ON:

SIGMA80, ALFA65, BETA65, LAMBDA65, YPSILON65

32

Double sowing drum.

AVAILABLE ON:

SIGMA80, ALFA65, BETA65/65C, LAMBDA65/65C, SEMBETA65, SEMLAMBDA65

33

Automatic recycling of the soil covering unit.

AVAILABLE ON:

SIGMA80, ALFA65, BETA65, LAMBDA65, YPSILON65

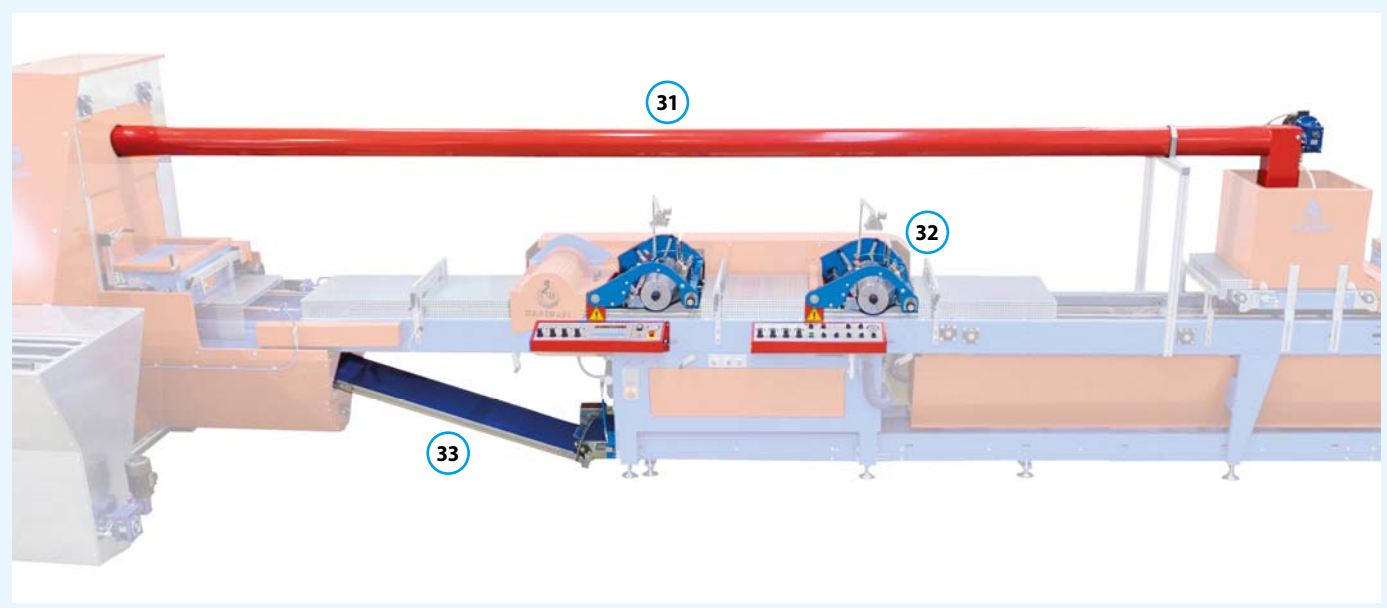

34

Frame completely made of stainless steel AISI304.

AVAILABLE ON:

ALL SEEDING LINES AND SEEDERS *except* SEMSF13

35

Seeding line with angular placing complete with transplanting belts. The U shape can also be selected.

AVAILABLE ON:  
ALL SEEDING LINES

